

SAPL 24 LTNP

Semi-trailer Plateau with a lightweight steel construction

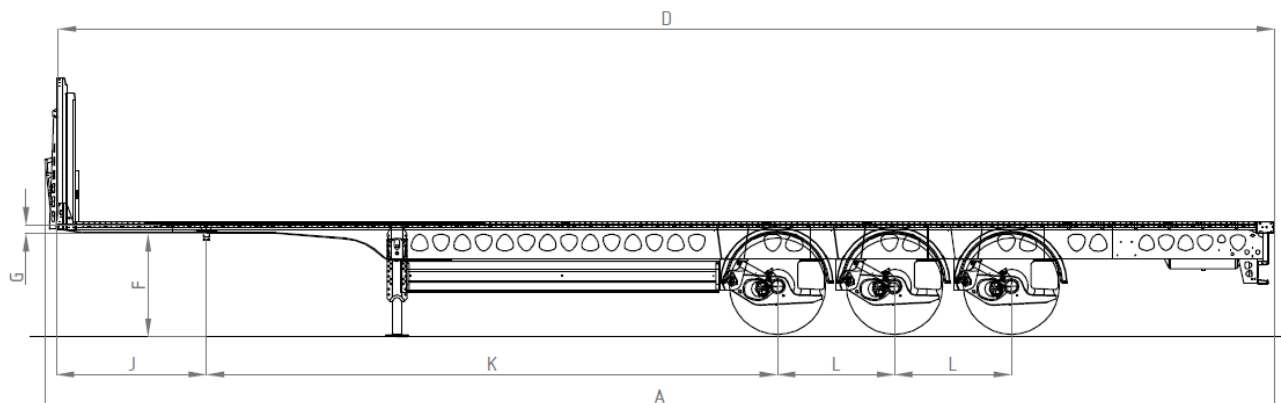

Technical Data (basic version)

	Tare weight	4.075	kgs
	Vertical load / technically possible	11.000/ 12.000	kgs
	Axle assembly load / technically possible	24.000/27.000	kgs
	Gross weight / technically possible	35.000/39.000	kgs
	Theoretical payload / technically possible	30.925/34.925	kgs
A	Total length	13.850	mm
	Vehicle width	2.550	mm
C	Total height unladen	2.880	mm
D	Loading length	13.620	mm
E	Loading width	2.490	mm
F	Coupling height (Attention: consider total height!)	1.150	mm
	Frame neck height (frame height over wheel coupling)	130	mm
	Front overhang / front overhand radius	1.680 /2.040	mm
	Wheel base	6.390	mm
	Axle spacing	1.310	mm
R	Height of front wall	1.600	mm
	Tyres	385/65 R22,5	6x
	Spring track / wheel track	1.300 / 2.040	mm
	Euro pallet capacity	34	Pcs.
P	Rear loading height, unladen (trailer in horizontal position)	1.280	mm

SAPL 24 LTNP

Semi-trailer Plateau with a lightweight steel construction



Technical Description (Basic Equipment):

- Welded frame construction made of fine-grained steel S700, cross beam spacing (Z-profiles) approx. 375 mm
- Mechanical landing gears 2 x 12 to
- SAF-brake system with disc brakes 370 mm; air suspension with raise/lowering device and operating valve at rear left
- Tires 6x, Goodyear, 385/65 R22.5, with steel rims
- EG- brake system type Knorr, mit Roll Stability Program (RSP), EBS 2S/2M, parking brake as spring brake with double release valve, aluminum compressed air tank, diagnostic capability via EBS socket ISO 7638
- 24 V lighting system, Hella, 2 x 7-pin and 1 x 15-pin plug socket according to DIN ISO 3731/12098, 2 multi-functional rear light systems (including rear fog lamp and reversing light), 2 clearance lights with rubber arms, 2 clearance lights (LED) on the front wall, 4 pairs of side marker lights (LED)
- Stable ecotrail-hybrid floor, GRP fabric on the underside as reinforcement and protection against moisture, floor sections tightly sealed on the outer frame, permissible forklift axle load 7,000 kg in accordance with DIN EN 283
- Smooth front wall with high-strength sandwich panel, additional vertical and horizontal reinforcement profiles, front wall stanchions and reinforcement profiles made of S700 fine-grain steel, front wall panels riveted to front wall stanchions, 200 mm high protective strip integrated at bottom of the front wall panels, front wall bolted to the chassis
- Rear portal bolted to the chassis, rear portal stanchions made of S700 fine-grain steel, covered, rubber buffer left/right
- 3 pairs of sliding stakes
- 18 pairs of lashing rings flush-fitted in outer frame, certified according to DIN EN 12640 for tensile loading of up to 2,500 daN
- Multifunctional perforated outer frame, 68 hook-in possibilities at spacing of 187 mm along the complete length of the outer frame on each side, lashing points certified according to DIN EN 12640 for tensile loading of up to 2,000 daN, other drilled holes available for additional fixing options of cargo control systems and other applications
- Practical equipment with semi-circular mudguards with integrated spray suppression according to 91/226/EEC
- 1 pc. of shim with holder
- Extendable rear access ladder
- 2 x ECE 70 reflectors mounted on the spacer sheet
- Underride guard and lateral protective according to regulations, each made of aluminium profiles
- Paintwork for chassis and landing gear, front wall panel (outer surface only) and front wall frame in an RAL colour according to the customer's request (no metallic or brilliant colours). Connection board on the front wall, lateral protective device including holder and landing gear cross-brace painted in RAL 9005 black, semi-gloss; underride guard and intermediate plates in anodized aluminium. Profiles and inaccessible areas additionally protected with cavity wax.