

# SAPL 20 LTMNP

2-axle semi-trailer Plateau  
with a lightweight steel construction, Mega

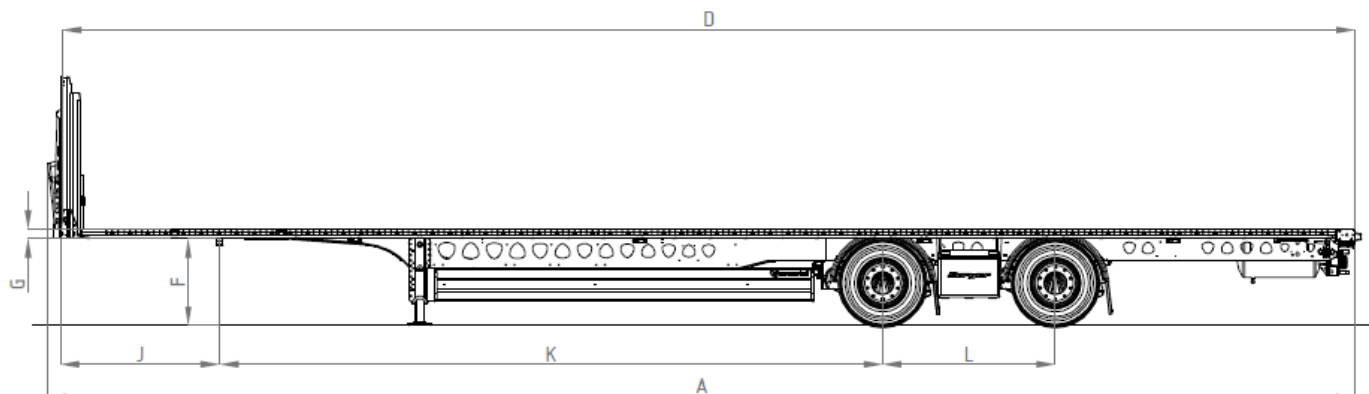

## Technical Data (basic version)

	<b>Tare weight</b>	<b>3.865</b>	<b>kgs</b>
	Vertical load / technically possible	11.000 / 12.000	kgs
	Axle assembly load / technically possible	20.000	kgs
	Gross weight / technically possible	31.000 / 32.000	kgs
	Theoretical payload / technically possible	27.135 / 28.135	kgs
<b>A</b>	Total length	13.850	mm
	Vehicle width	2.550	mm
	Total height unladen	2.650	mm
<b>D</b>	Loading length	13.620	mm
	Loading width	2.490	mm
<b>F</b>	Coupling height (Attention: consider total height!)	920	mm
<b>G</b>	Frame neck height (frame height over wheel coupling)	90	mm
<b>J</b>	Front overhang / front overhand radius	1.680 / 2.040	mm
<b>K</b>	Wheel base	6.390	mm
<b>L</b>	Axle spacing	1.820	mm
	Height of front wall	1.600	mm
	Tyres	435/50 R19,5	6x
	Spring track / wheel track	1.300 / 2.040	mm
	Euro pallet capacity	34	Pcs.
	Rear loading height, unladen (trailer in horizontal position)	1.010	mm

# SAPL 20 LTMNP

2-axle semi-trailer Plateau  
with a lightweight steel construction, Mega



## Technical Description (Basic Equipment):

- Welded frame construction made of fine-grained steel S700, cross beam spacing (Z-profiles) approx. 375 mm
- Mechanical landing gears 2 x 12 to
- SAF-brake system with disc brakes 370 mm; air suspension with raise/lowering device and operating valve at rear left
- Tires 4x, Goodyear, 435/50 R19.5, with steel rims, 5tons
- EG- brake system type Knorr, mit Roll Stability Program (RSP), EBS 2S/2M, parking brake as spring brake with double release valve, aluminum compressed air tank, diagnostic capability via EBS socket ISO 7638
- 24 V lighting system, Hella, 2 x 7-pin and 1 x 15-pin plug socket according to DIN ISO 3731/12098, 2 multi-functional rear light systems (including rear fog lamp and reversing light), 2 clearance lights with rubber arms, 2 clearance lights (LED) on the front wall, 4 pairs of side marker lights (LED)
- Stable ecotrail-hybrid floor, GRP fabric on the underside as reinforcement and protection against moisture, floor sections tightly sealed on the outer frame, permissible forklift axle load 7,000 kg in accordance with DIN EN 283
- Smooth front wall with high-strength sandwich panel, additional vertical and horizontal reinforcement profiles, front wall stanchions and reinforcement profiles made of S700 fine-grain steel, front wall panels riveted to front wall stanchions, 200 mm high protective strip integrated at bottom of the front wall panels, front wall bolted to the chassis
- Rear portal bolted to the chassis, rear portal stanchions made of S700 fine-grain steel, covered, rubber buffer left/right
- 18 pairs of lashing rings flush-fitted in outer frame, certified according to DIN EN 12640 for tensile loading of up to 2,500 daN
- Multifunctional perforated outer frame, 68 hook-in possibilities at spacing of 187 mm along the complete length of the outer frame on each side, lashing points certified according to DIN EN 12640 for tensile loading of up to 2,000 daN, other drilled holes available for additional fixing options of cargo control systems and other applications
- Practical equipment with semi-circular mudguards with integrated spray suppression according to 91/226/EEC
- 1 pc. of shim with holder
- Extendable rear access ladder
- ECE 70 reflector mounted on the spacer sheet
- Underride guard and lateral protective according to regulations, each made of aluminium profiles
- Paintwork for chassis and landing gear, front wall panel (outer surface only) and front wall frame in an RAL colour according to the customer's request (no metallic or brilliant colours). Connection board on the front wall, lateral protective device including holder and landing gear cross-brace painted in RAL 9005 black, semi-gloss; underride guard and intermediate plates in anodized aluminium. Profiles and inaccessible areas additionally protected with cavity wax.